

4709

419

5 cm

PROPOSED ARRANGEMENT

LOW PRESSURE GAUGE
0 - 1000 p.s.i.

EXISTING HIGH PRESS. GAUGE
1000 - 10000 p.s.i.
160mm. diameter

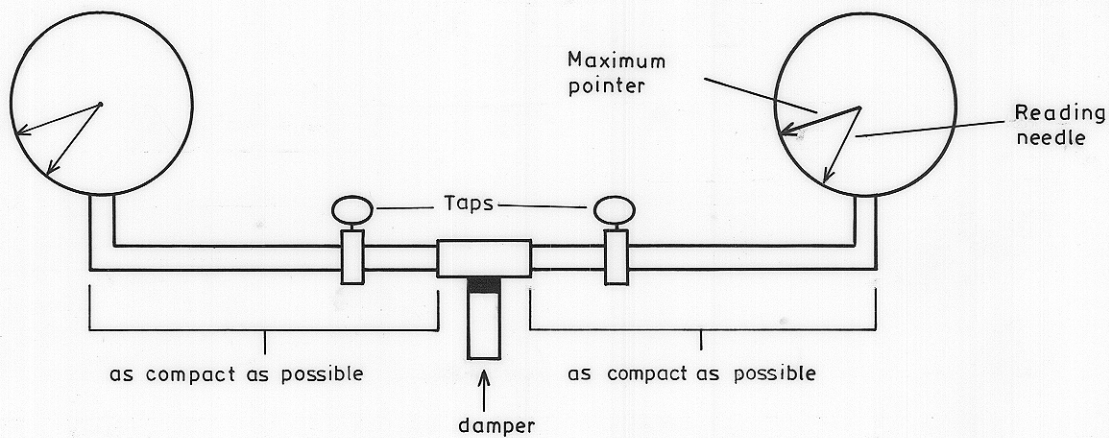

PRESENT ARRANGEMENT

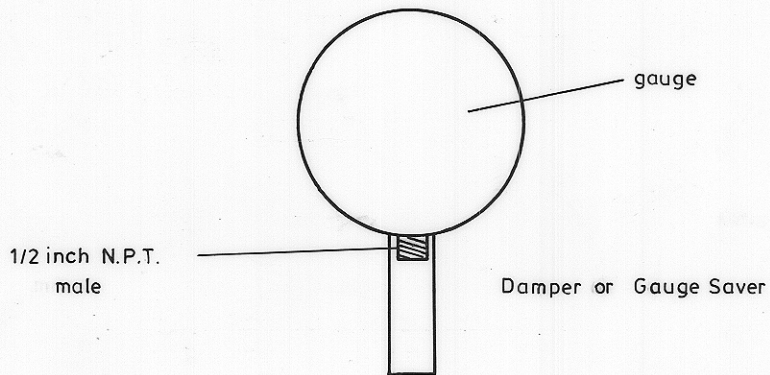

Oct 1980

4709