

5 cm

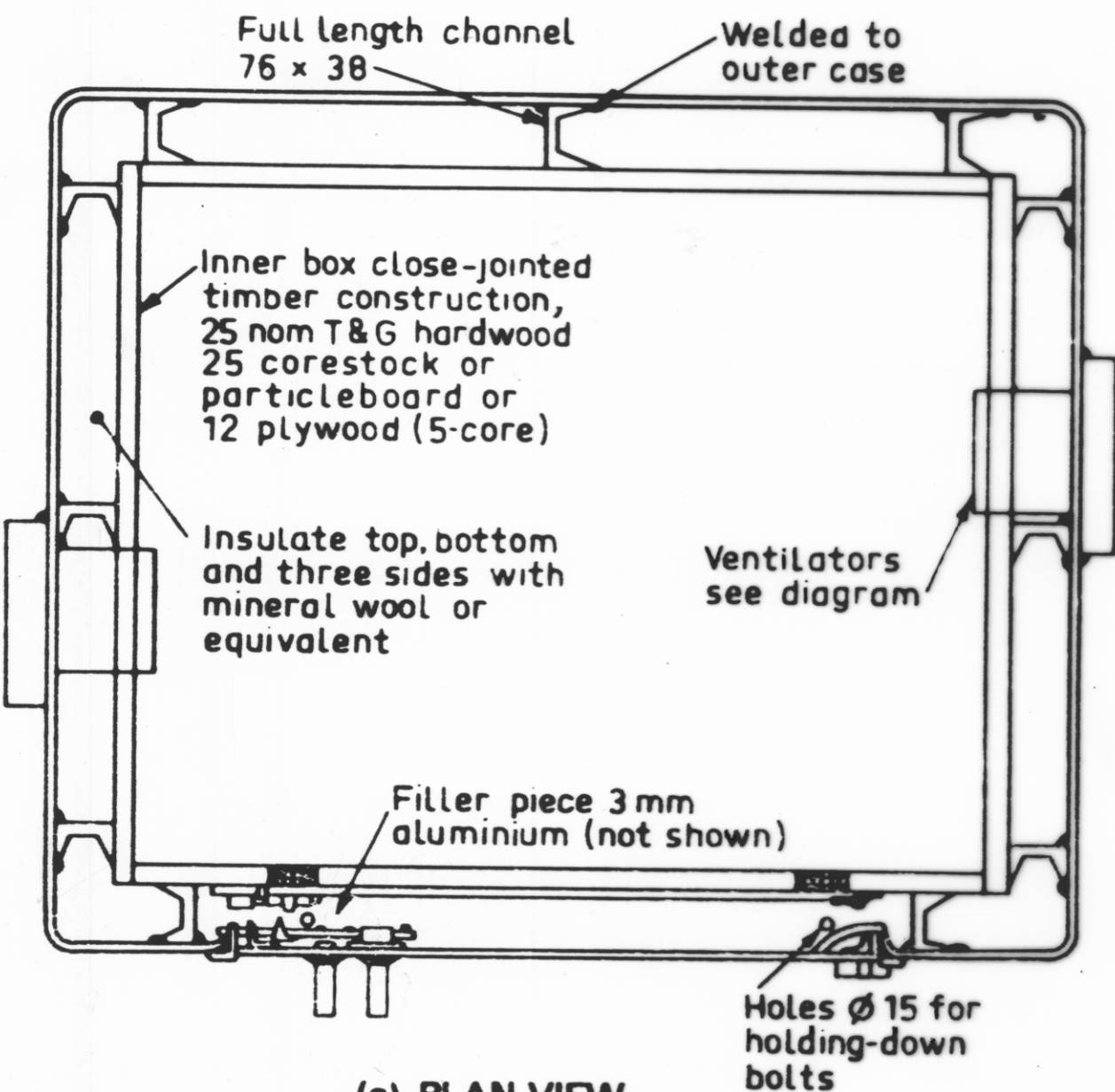

(a) PLAN VIEW

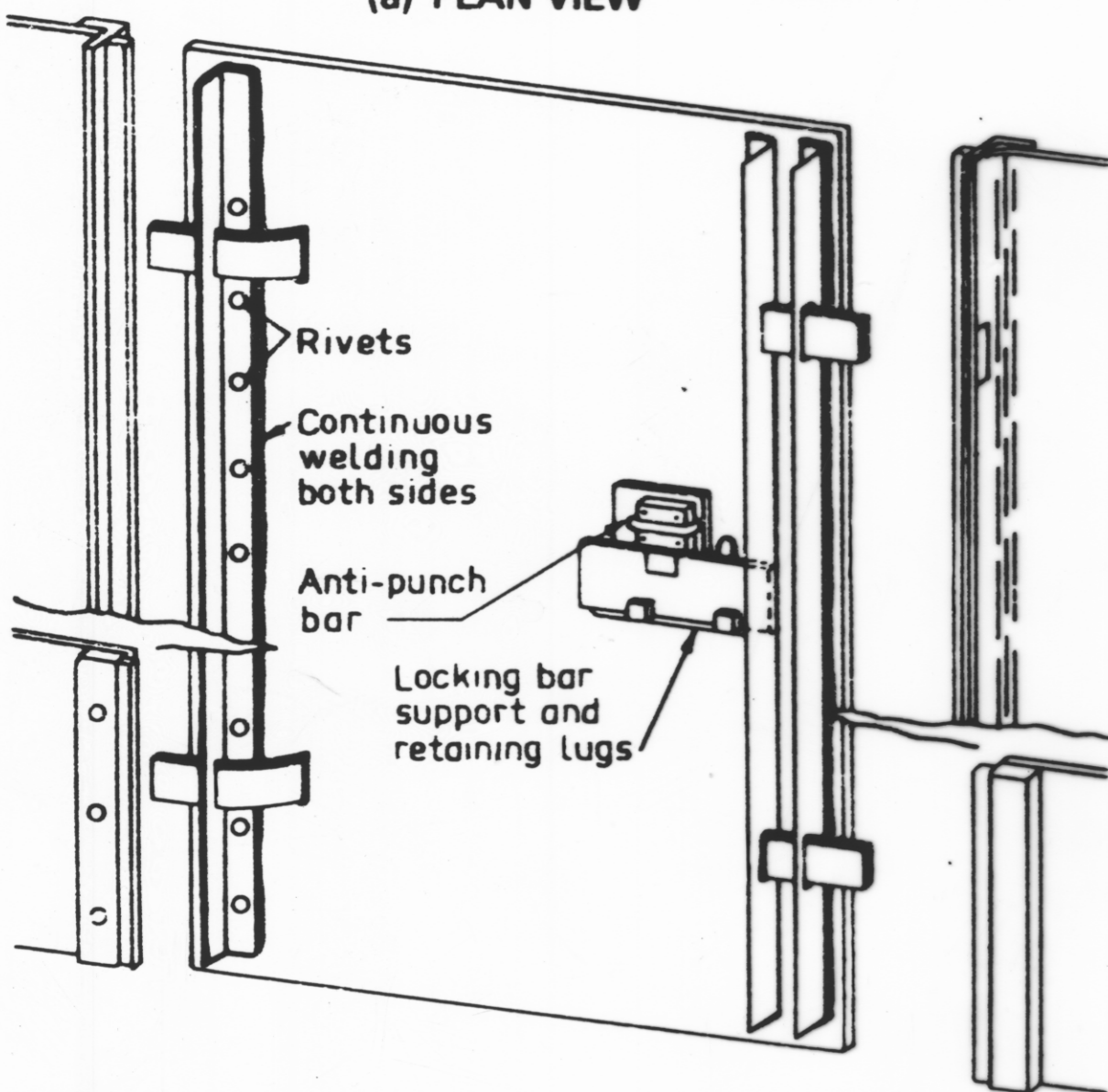

(d) LOCKING DEVICES

NOTE: This section shows alternative methods of frame construction.

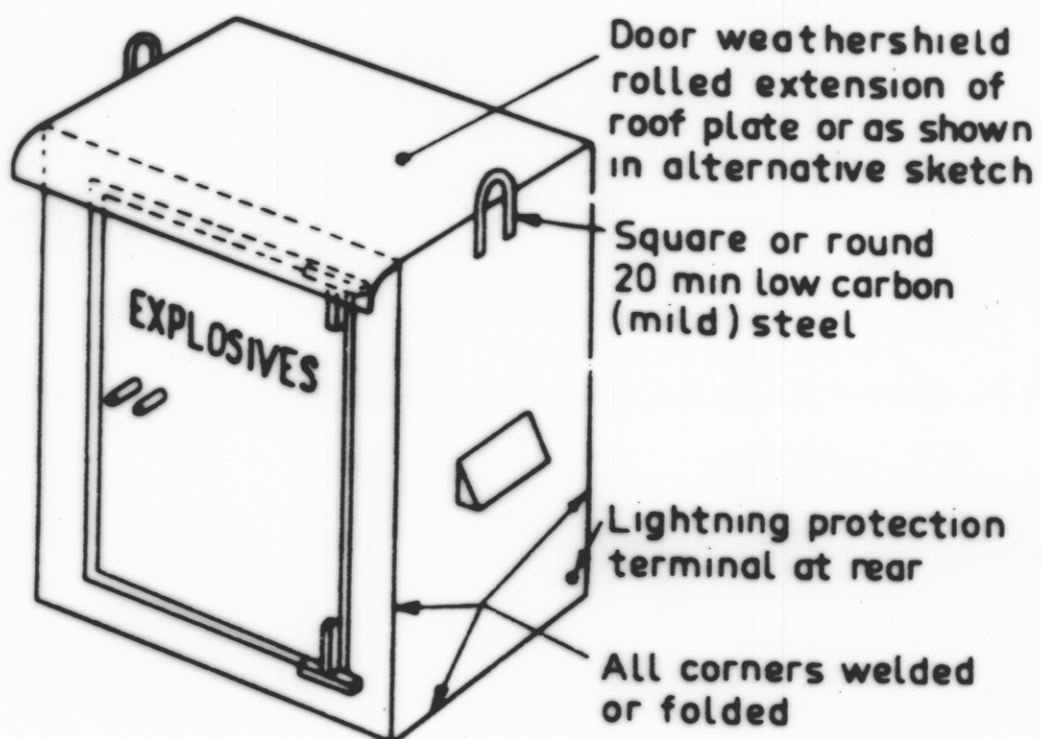

(b) ISOMETRIC VIEW

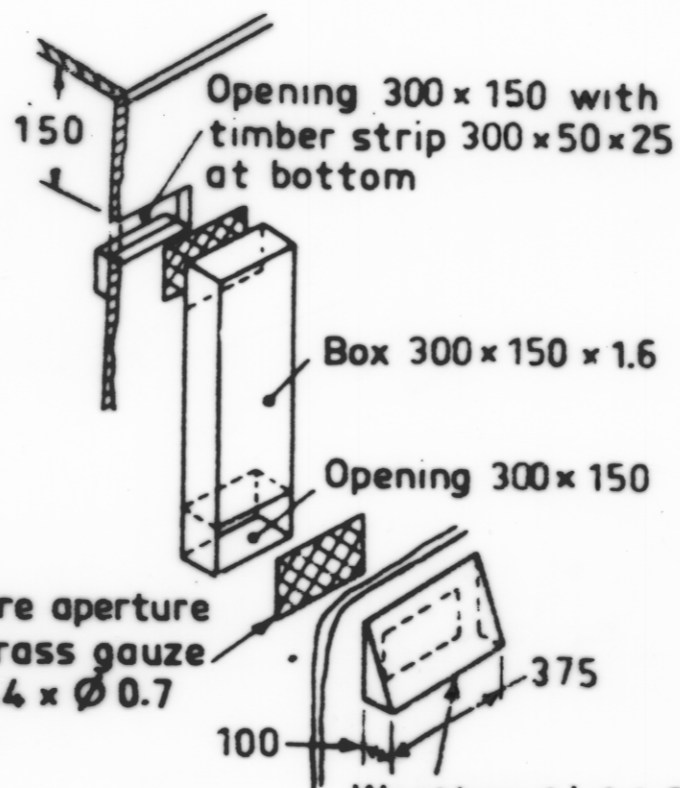
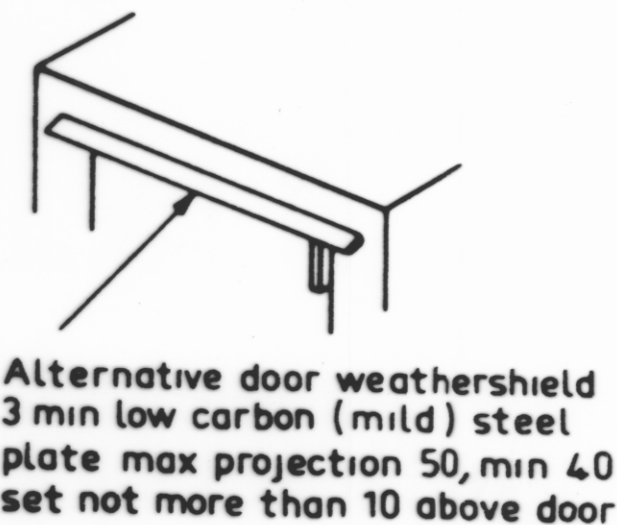

(c) VENTILATOR DETAILS

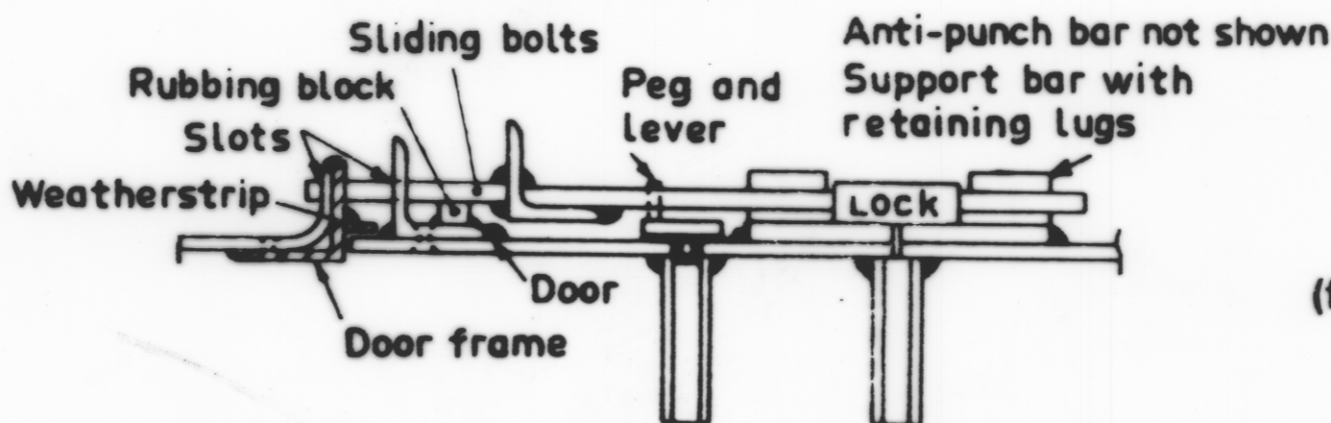

(e) SECTION SHOWING TYPICAL LOCK ARRANGEMENT

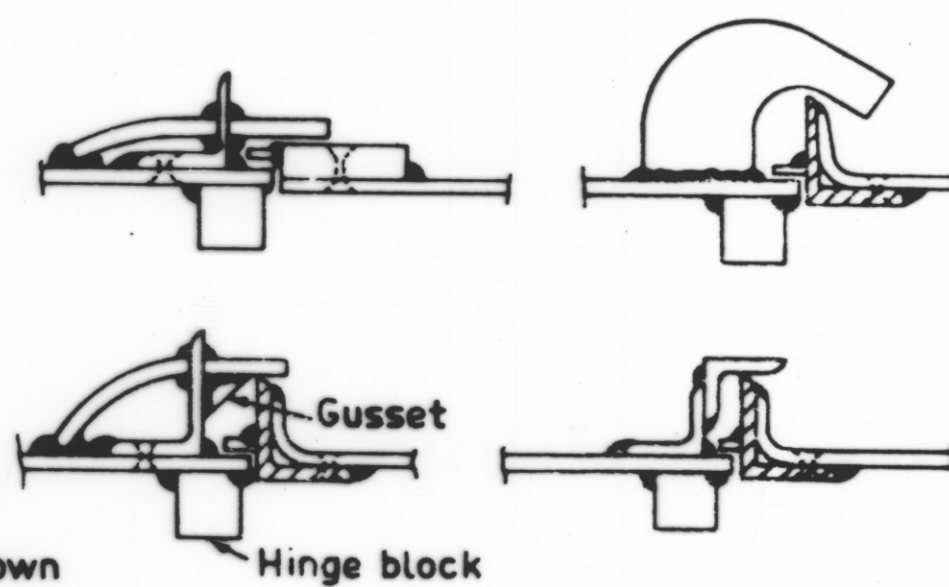

(ii) Four types of door arrangements (hinged side)

(f) ALTERNATIVE LOCKING ARRANGEMENTS

ALL DIMENSIONS ARE IN MILLIMETRES

Fig. A1. MAGAZINE CONSTRUCTION DETAILS